

The influence of graphene curvature and functionalization on hydrogen adsorption: towards hydrogen storage devices

Stefan Heun

*NEST, Istituto Nanoscienze-CNR and Scuola Normale Superiore
Pisa, Italy*



National Enterprise for nanoScience and nanoTechnology

NEST

Outline

- Presentation of NEST
- Introduction to Hydrogen Storage
- Epitaxial Graphene
- Hydrogen Storage by Corrugation
- Hydrogen Storage by Functionalization

Outline

- Presentation of NEST
- Introduction to Hydrogen Storage
- Epitaxial Graphene
- Hydrogen Storage by Corrugation
- Hydrogen Storage by Functionalization

NEST Pisa



NEST Pisa

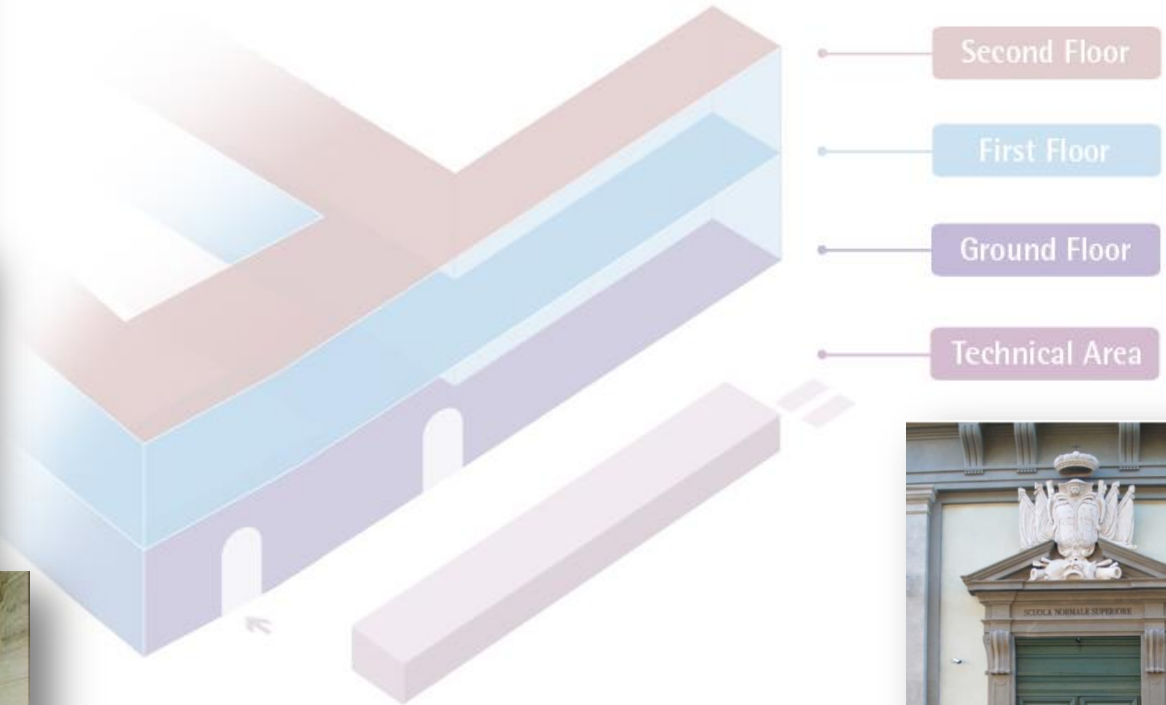
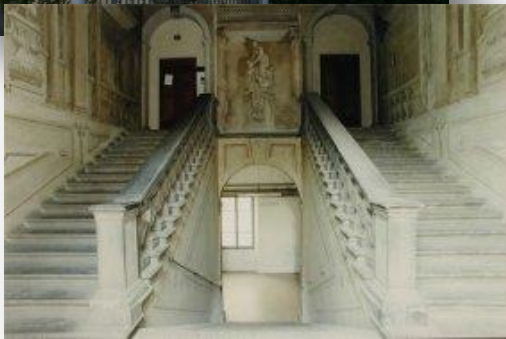



NEST Pisa

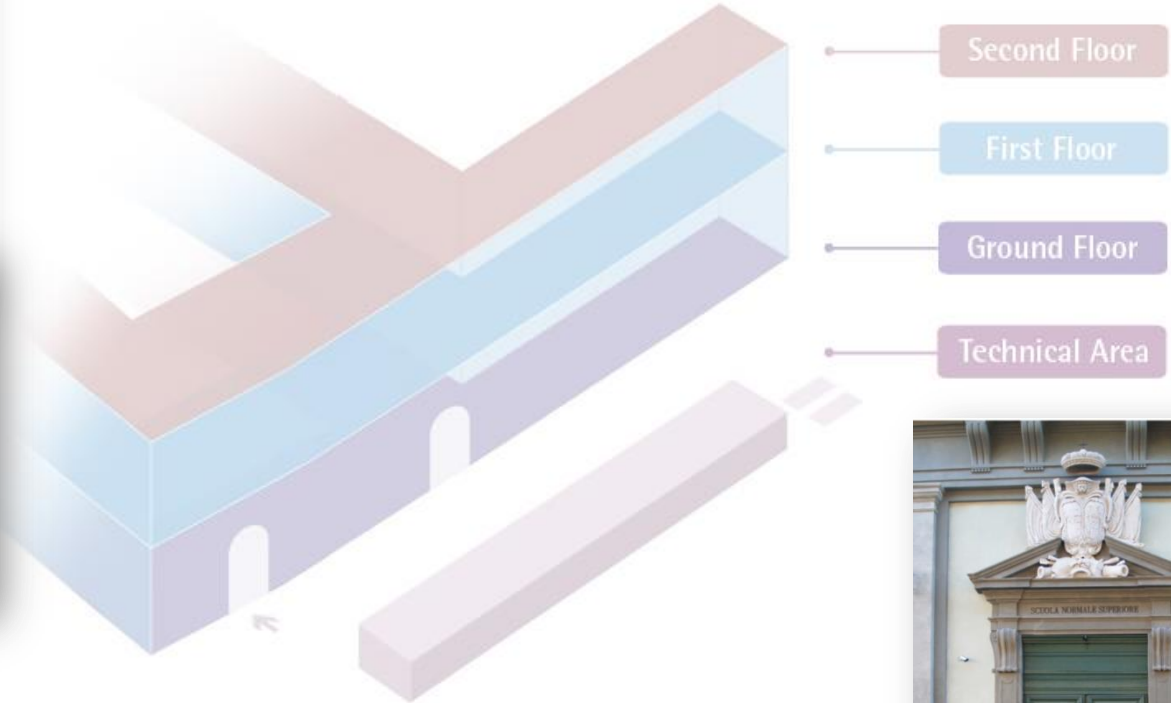

National Enterprise for nanoScience and nanoTechnology



SCUOLA
NORMALE
SUPERIORE
PISA



ISTITUTO ITALIANO
DI TECNOLOGIA



NEST Pisa



- **CNR:** Vittorio Pellegrini, Valentina Tozzini, Stefan Heun
- **IIT:** Camilla Coletti, Vincenzo Piazza, Sarah Goler, Torge Mashoff
- **SNS:** Massimo Morandini, Pasquale Pingue, Fabio Beltram

NEST facilities

- UHV VT STM

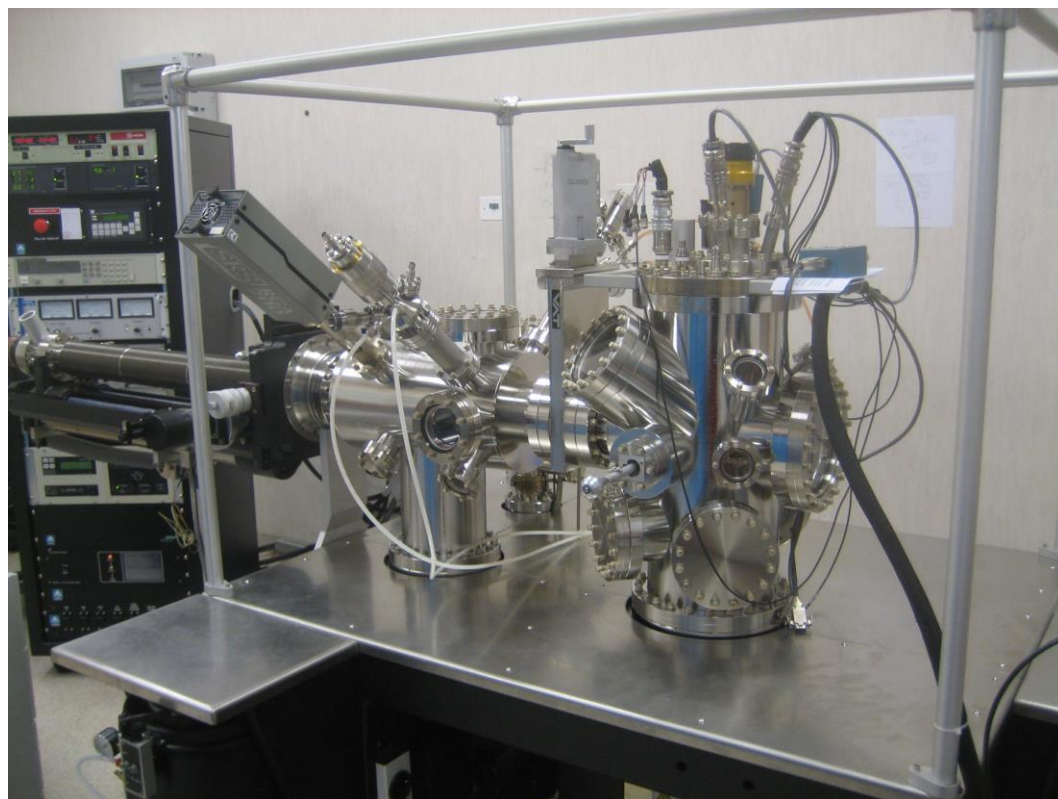
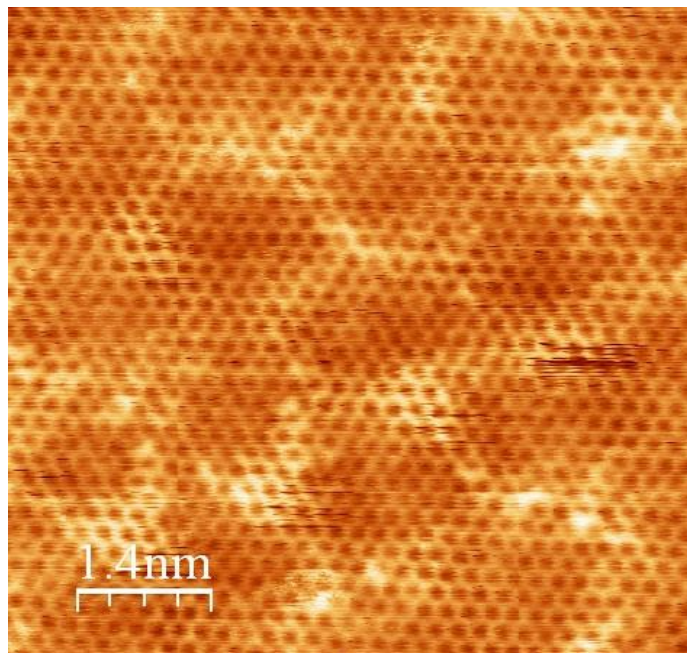

NEST facilities

- UHV VT STM
- Graphene Growth



NEST facilities

- UHV VT STM
- Graphene Growth
- Micro-Raman

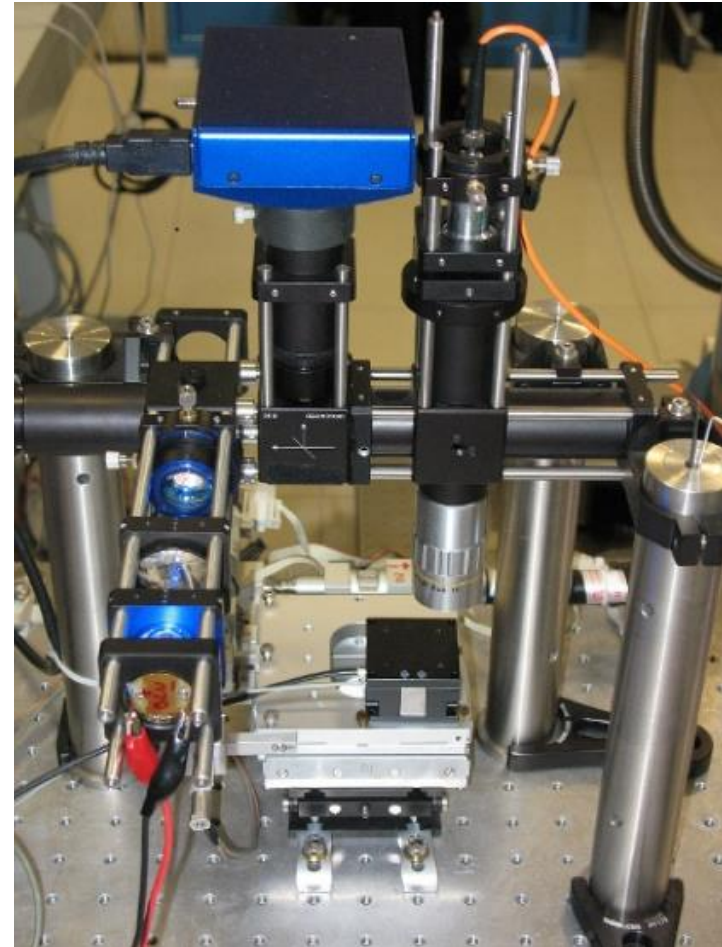

NEST facilities

- UHV VT STM
- Graphene Growth
- Micro-Raman
- AFM



NEST facilities

- UHV VT STM
- Graphene Growth
- Micro-Raman
- AFM
- SEM



NEST facilities

- UHV VT STM
- Graphene Growth
- Micro-Raman
- AFM
- SEM
- Theory



Outline

- Presentation of NEST
- Introduction to Hydrogen Storage
- Epitaxial Graphene
- Hydrogen Storage by Corrugation
- Hydrogen Storage by Functionalization

Hydrogen & energy

As a **fuel**, hydrogen has advantages:

- high energy-to-mass ratio
- $\text{H}_2 + 1/2 \text{O}_2 \rightarrow \text{H}_2\text{O} \quad \Delta H = -2.96\text{eV}$
- Non-toxic and “clean” (product = water)
- renewable

However, hydrogen is NOT an **energy source**: it must be produced e.g. by electrolysis, needing +2.96 eV, with zero balance with respect to energy production.

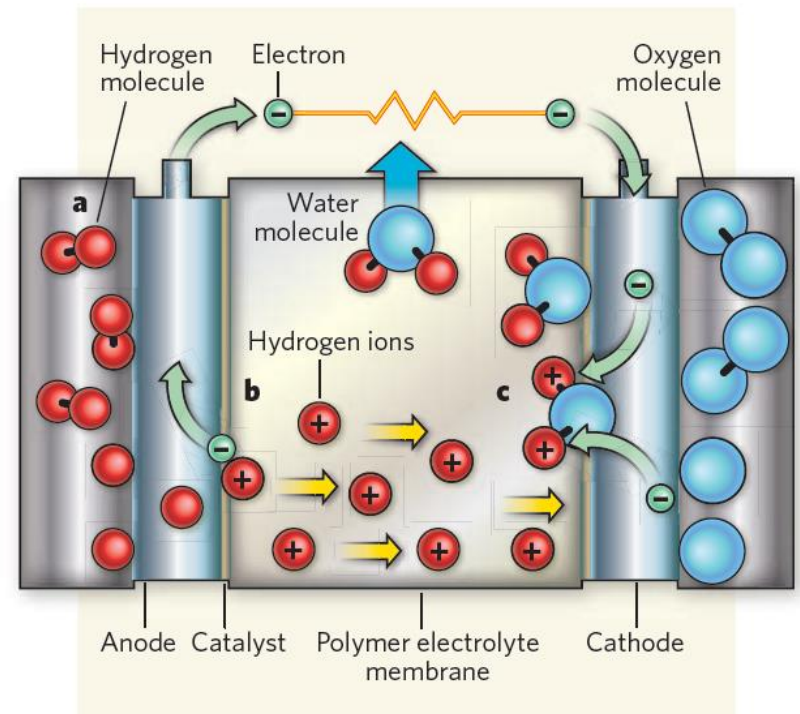





Hydrogen fuel cell

Hydrogen-fuelled vehicles

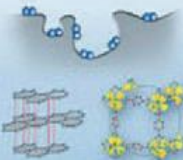
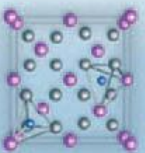

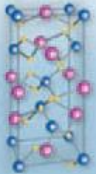
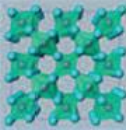
Hydrogen Storage

						
Liquid hydrogen	Cryo-adsorption	Interstitial metal hydride	Compressed hydrogen	Aluminate	Salt-like metal hydride	Water
LH2	Activated carbon	Laves Phase Comp./ FeTiH _x / LaNi ₅ H _x	CGH2	NaAlH ₄	MgH ₂	H ₂ O
100 mat.wt%	6.5 mat.wt%	2 mat.wt%	100 mat.wt%	5.5 mat.wt%	7.5 mat.wt%	11 mat.wt%
Operating temperature						
-253°C	> -200°C	0 - 30°C	25°C	70 - 170°C	330°C	>> 1000°C

Targets for **transport applications** not reached yet:

$$\rho_m > 5.5 \text{ wt\%}$$

$$\rho_v > 50 \text{ kg H}_2 / \text{m}^3$$

$$P_{eq} \approx 1 \text{ bar at } T < 100^\circ\text{C}$$

Compressed H₂:

High pressure and heavy container to support such pressure

Solid State:

Physisorption
Chemisorption

Liquid H₂:

Liquefaction needs energy and consumes more than 20% of the recoverable energy

Graphene for hydrogen storage

- Graphene is lightweight, inexpensive, robust, chemically stable
- Large surface area ($\sim 2600 \text{ m}^2/\text{g}$)
- Functionalized graphene has been predicted to adsorb up to 9 wt% of hydrogen

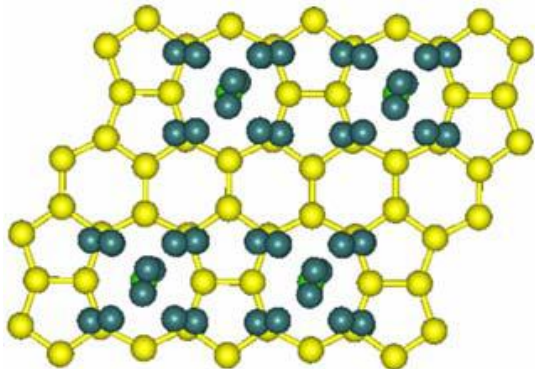

Yang et al., PRB 79 (2009) 075431

H storage in graphene

❖ Atomic hydrogen chemisorption has a small or negligible chemisorption barrier \Rightarrow feasible but H_2 must be cracked

❖ Physisorption weakly binds hydrogen \Rightarrow acceptable storage densities only at low temperatures and/or high pressure

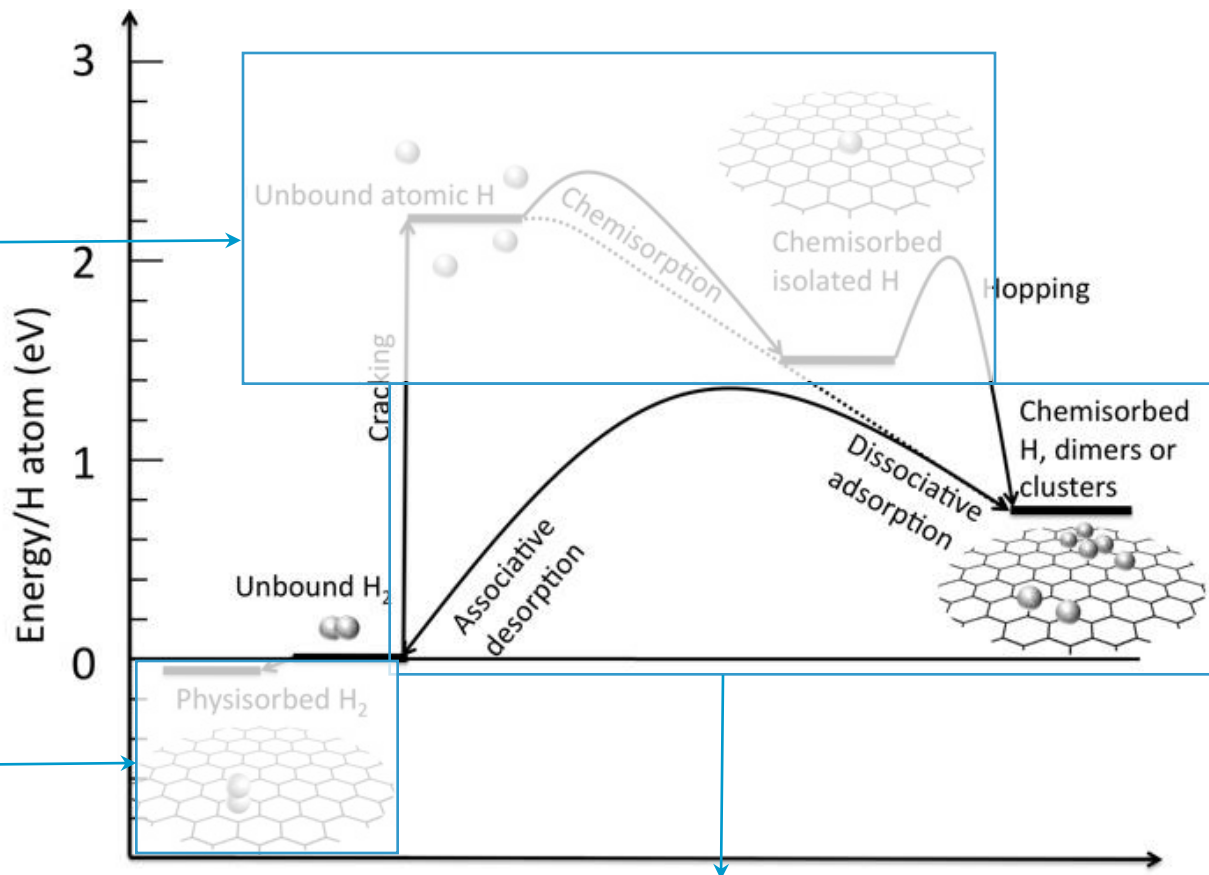

❖ Molecular hydrogen chemi(de)sorption has high barrier (theoretical estimate \sim eV) \Rightarrow chemisorbed H is stable for transportation etc, but catalytic mechanisms are necessary in the loading-release phases

Outline

- Presentation of NEST
- Introduction to Hydrogen Storage
- Epitaxial Graphene
- Hydrogen Storage by Corrugation
- Hydrogen Storage by Functionalization

What is Graphene?

A **SINGLE** layer of carbon atoms!

The atoms are arranged in a honeycomb lattice composed of two intertwined equivalent sublattices.

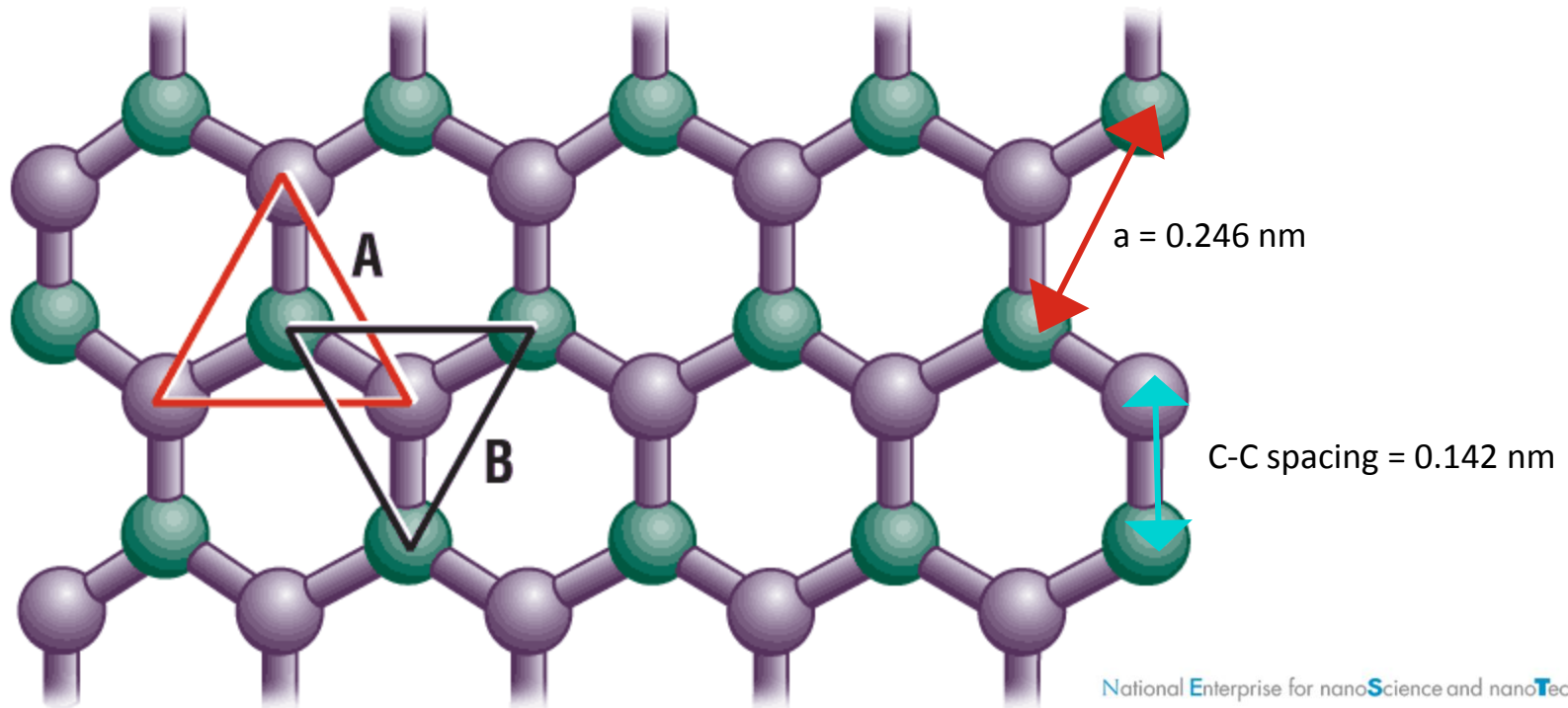

Graphene growth on SiC

Graphene or thin graphite films form on SiC surfaces upon annealing at high temperatures as a result of SiC decomposition.

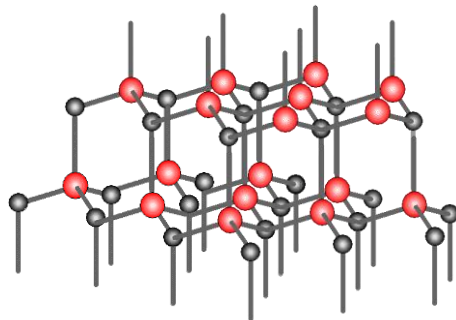
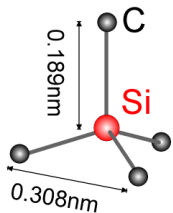
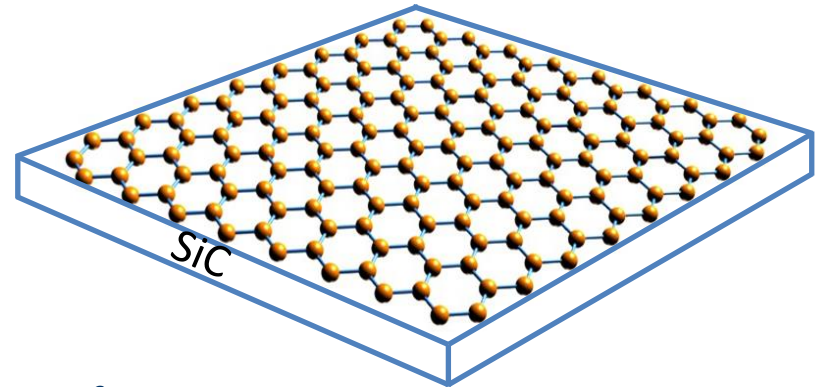

Bilayer of Si-C tetrahedra

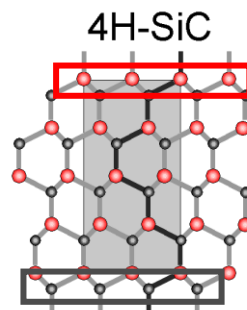
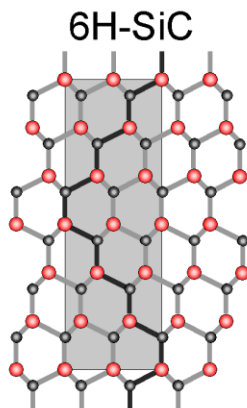
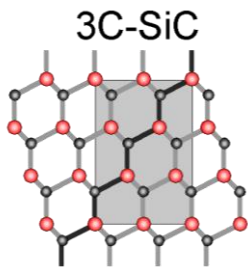

Graphene:
Ordered stacking
Si(0001) face → Good thickness control

Graphene:
Rotational disorder
C(000 $\bar{1}$) face → Poor thickness control

Graphene growth on SiC(0001)

Commercially available SiC:
polishing scratches

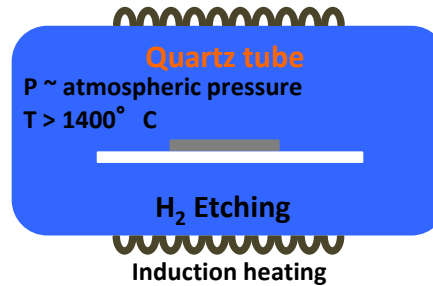
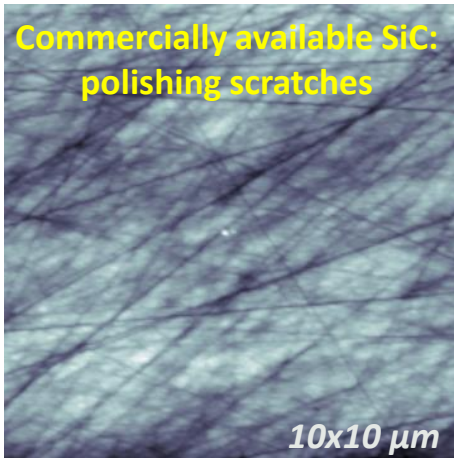

C. Coletti et al., *Appl. Phys. Lett.* 91, 061914 (2007)



Atomically flat SiC

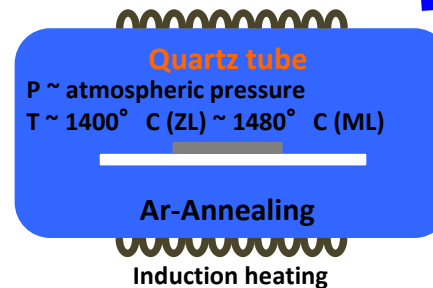
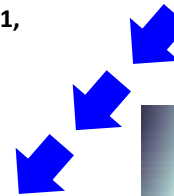
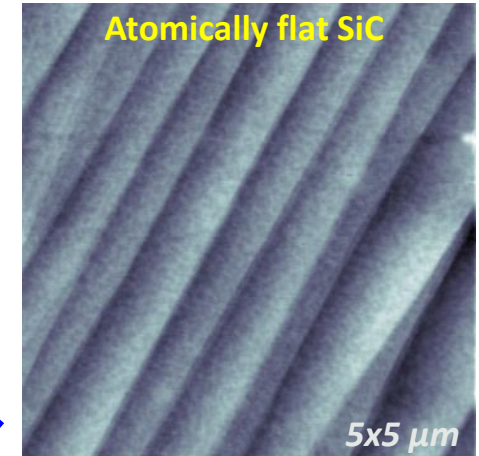

K.Emtsev et al., *Nature Mater.* 8, 203 (2009)



Homogenous graphene

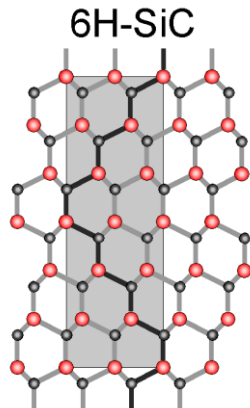
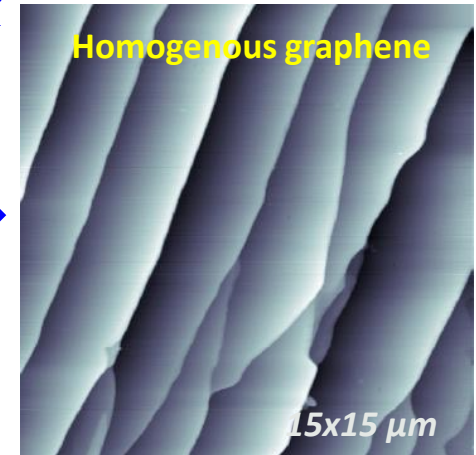

Graphene growth on SiC(0001)

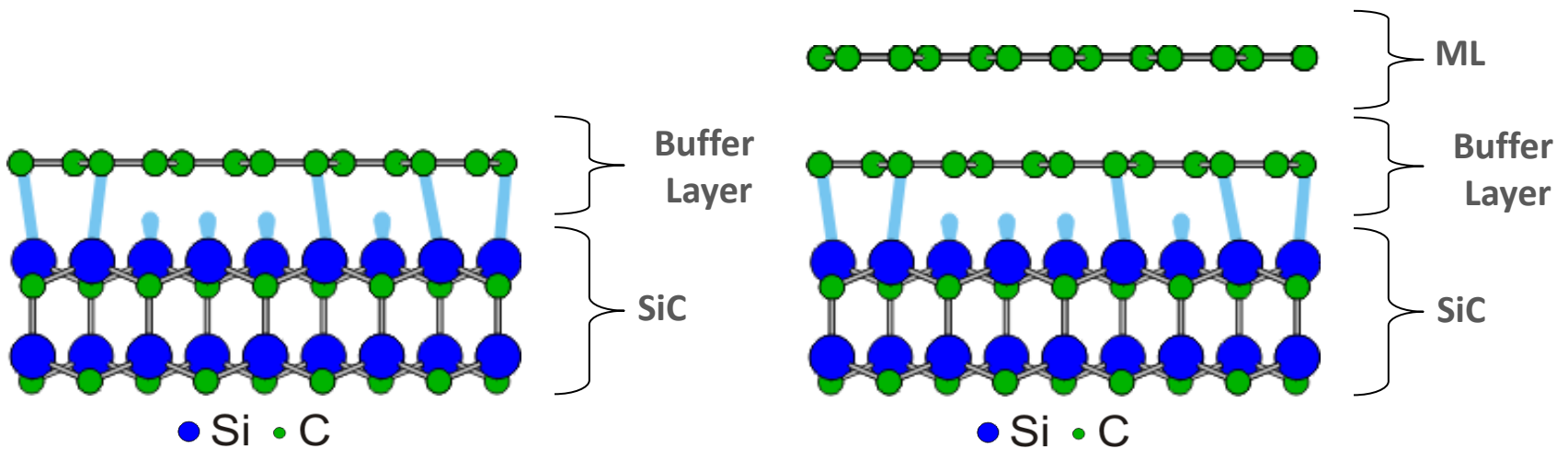

Buffer Layer

Topologically identical atomic carbon structure as graphene. Does not have the electronic band structure of graphene due to periodic sp^3 C-Si bonds.

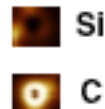
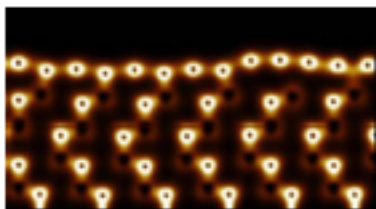

F. Varchon, et al., PRB 77, 235412 (2008).

Theoretical Calculations

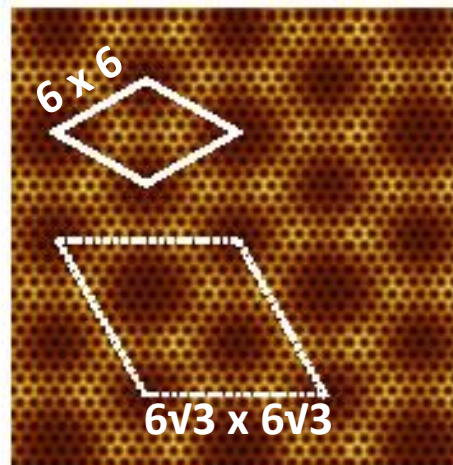

F. Varchon, et al., PRB 77, 235412 (2008).

Superstructure of both the buffer layer and monolayer graphene on the Si face from the periodic interaction with the substrate.

Buffer Layer

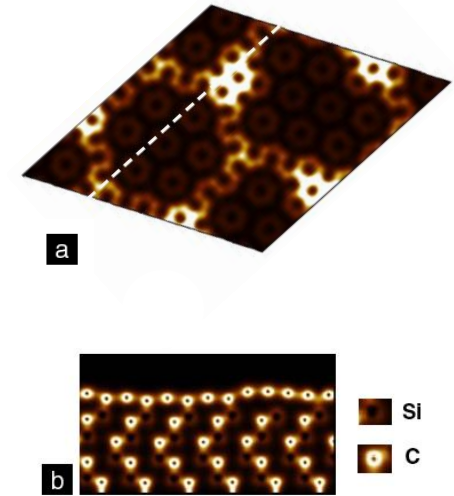
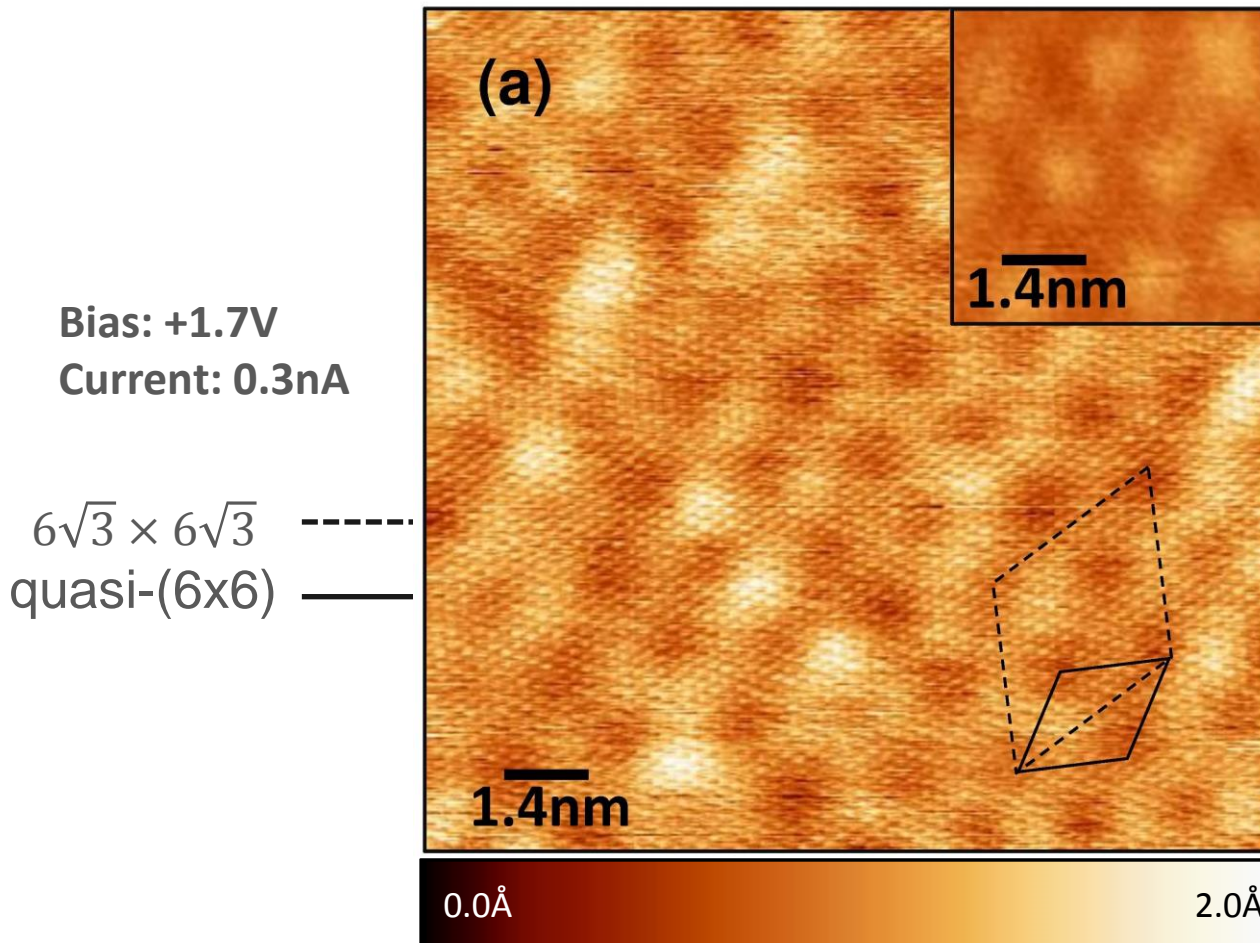
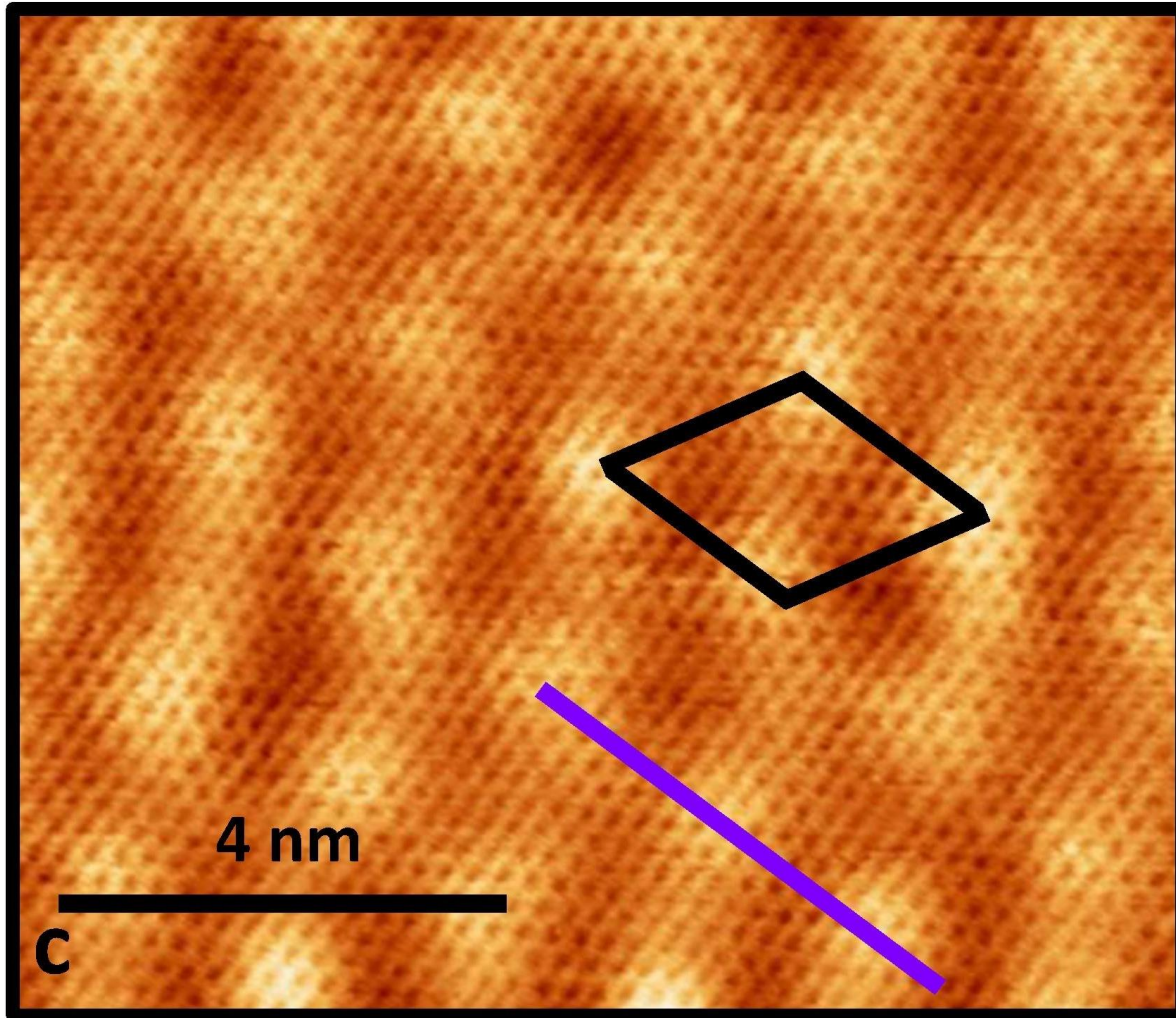

FIG. 2. (Color online) Total charge density of the buffer layer on SiC(001). (a) total charge density in the $6R3$ -SiC unit cell. (b) cross section of the total charge density along the line defined in (a). The black dots that appear when the cross section goes through the middle of an atom are due to the use of pseudopotentials (no core electrons).

F. Varchon, et al., PRB 77, 235412 (2008).

Monolayer Graphene



STM

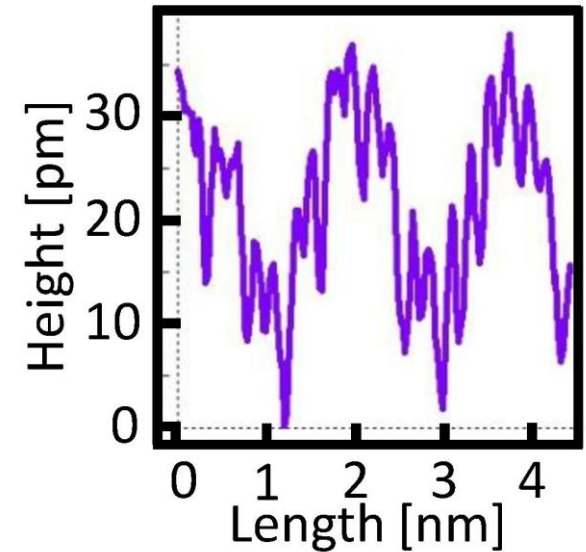

$6\sqrt{3} \times 6\sqrt{3}$ -Superstructure

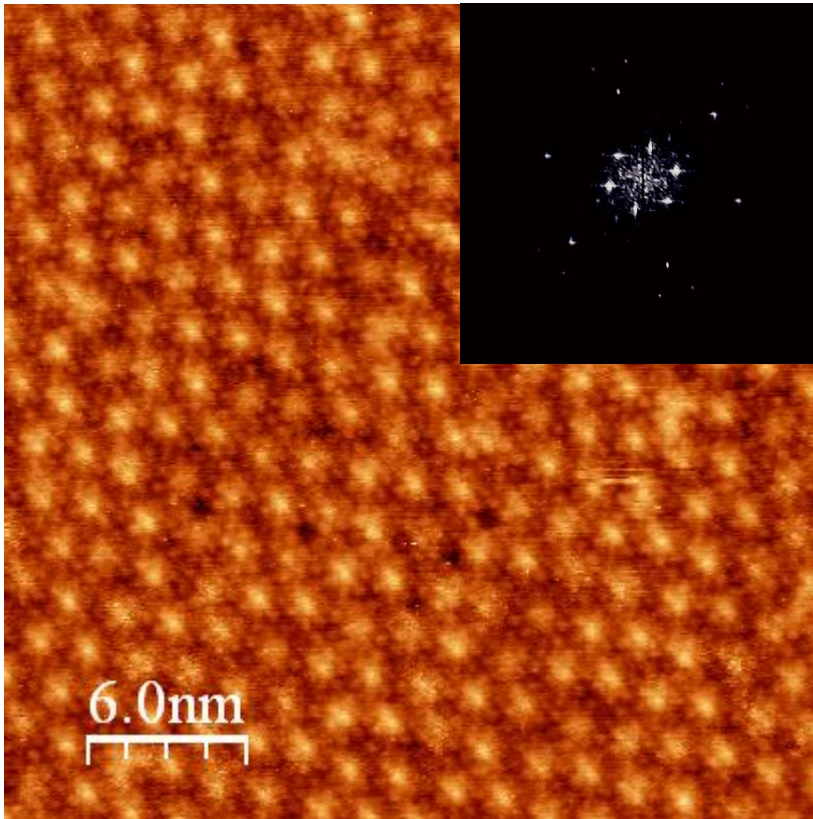

30 nm, 1V, 100 pA

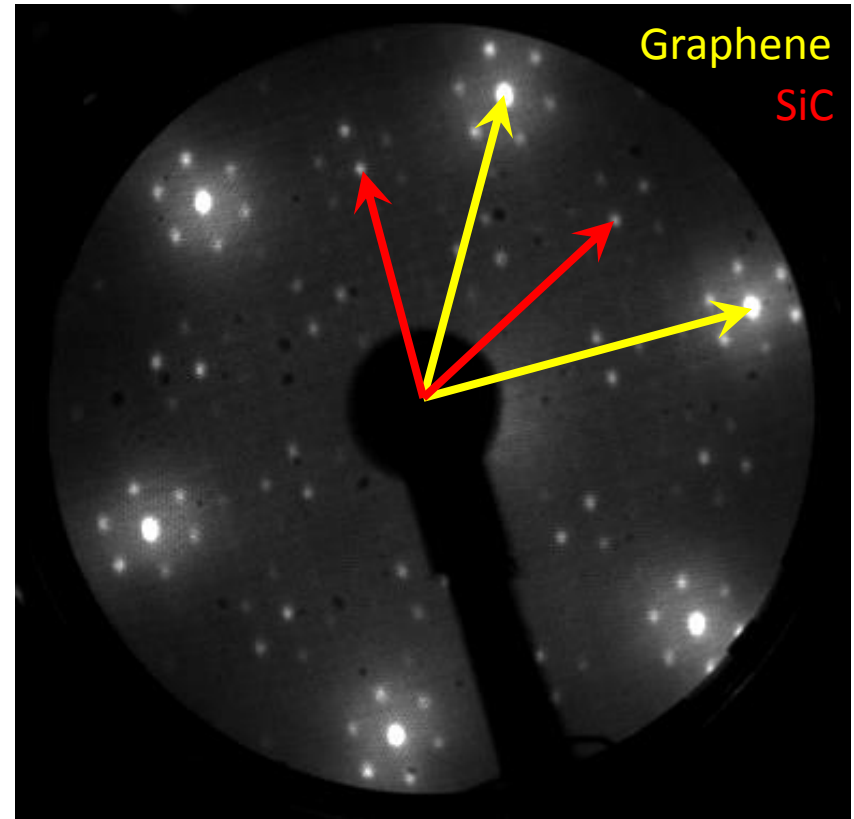

E= 75 eV

ML: Micro-Raman

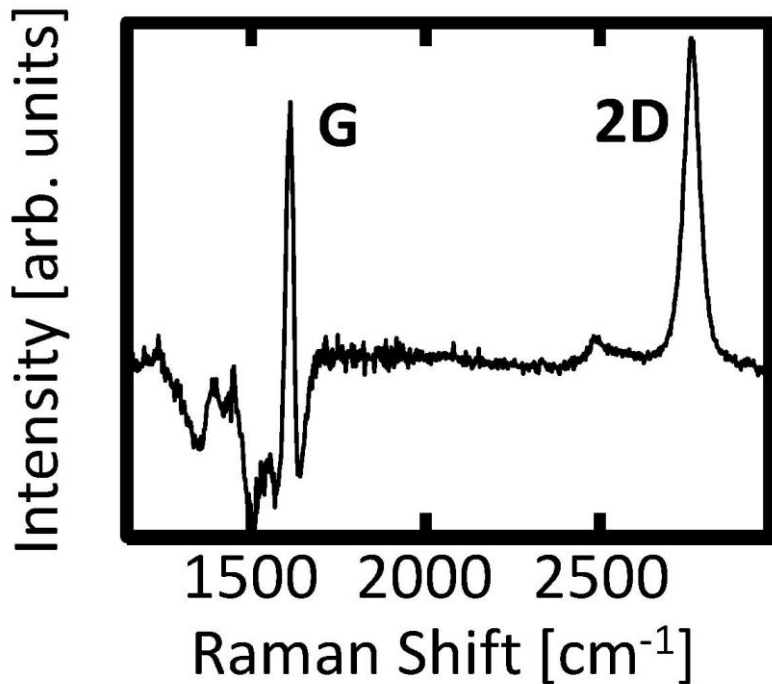

Spectrum from 12um x 12um area
SiC background subtracted

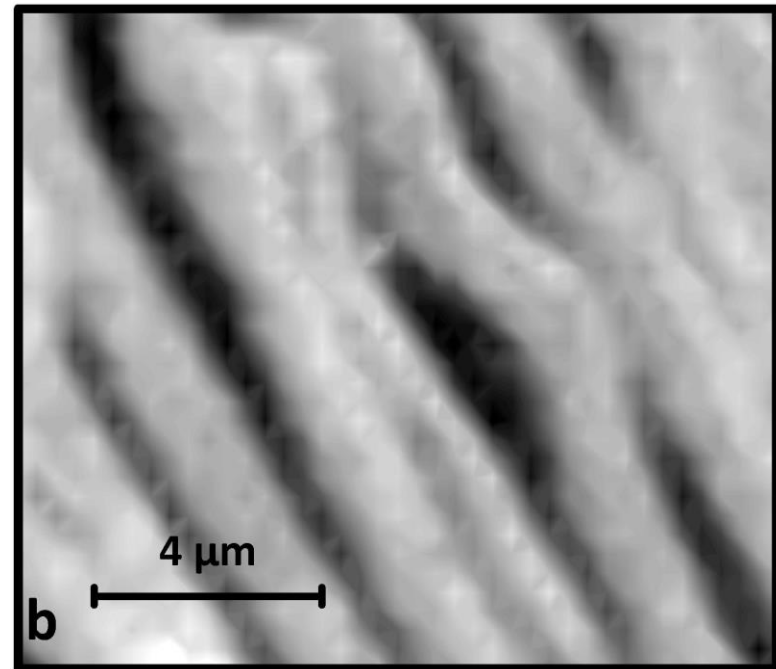

Integrated intensity of 2D peak
Bright = ML graphene

Outline

- Presentation of NEST
- Introduction to Hydrogen Storage
- Hydrogen Storage by Corrugation
- Hydrogen Storage by Functionalization

Graphene Curvature

- Exploit graphene curvature for hydrogen storage at room temperature and pressure

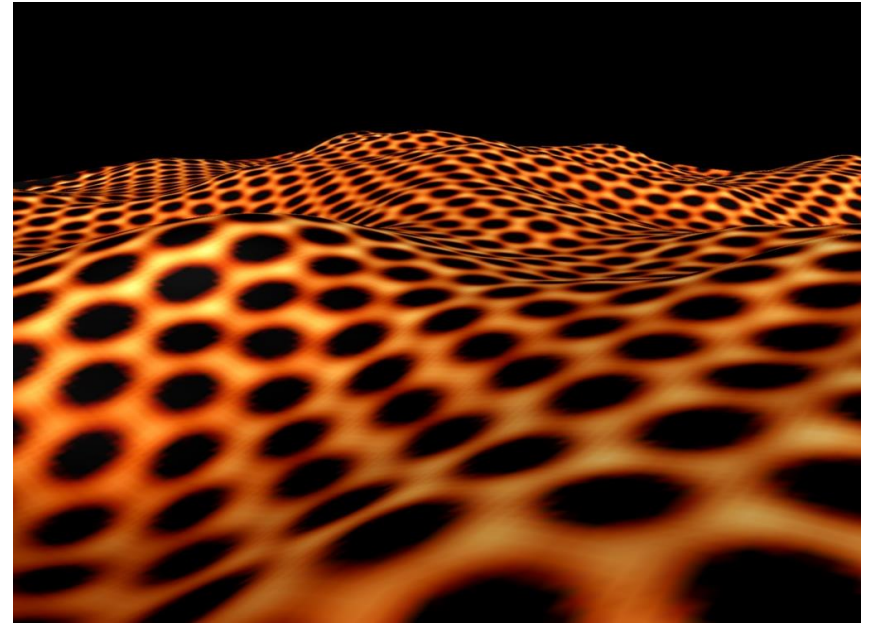

Graphene Curvature

- Exploit graphene curvature for hydrogen storage at room temperature and pressure
- The hydrogen binding energy on graphene is strongly dependent on local curvature and it is larger on convex parts

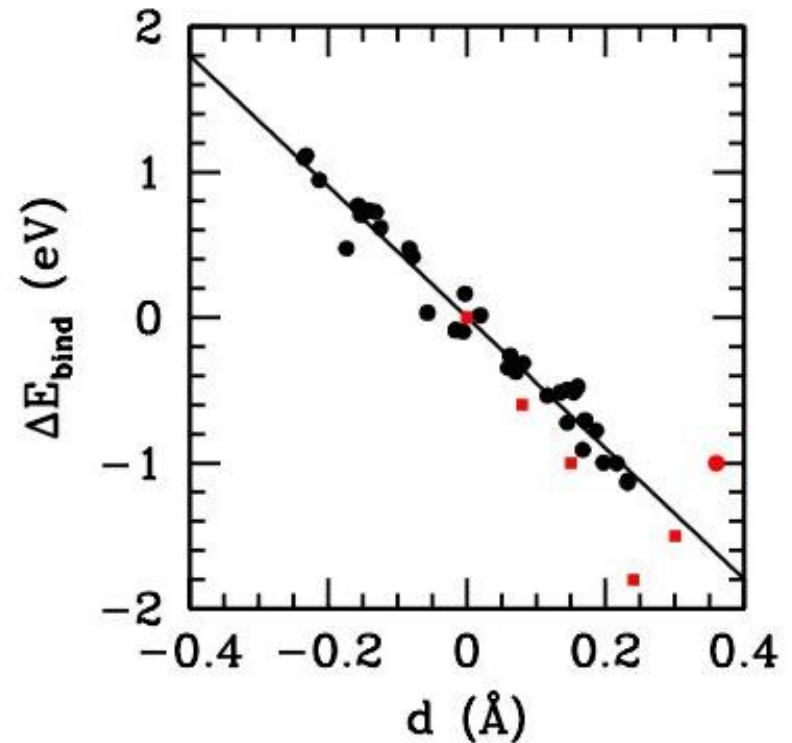

Graphene Curvature

- Exploit graphene curvature for hydrogen storage at room temperature and pressure
- The hydrogen binding energy on graphene is strongly dependent on local curvature and it is larger on convex parts
- Atomic hydrogen spontaneously sticks on convex parts; inverting curvature H is expelled

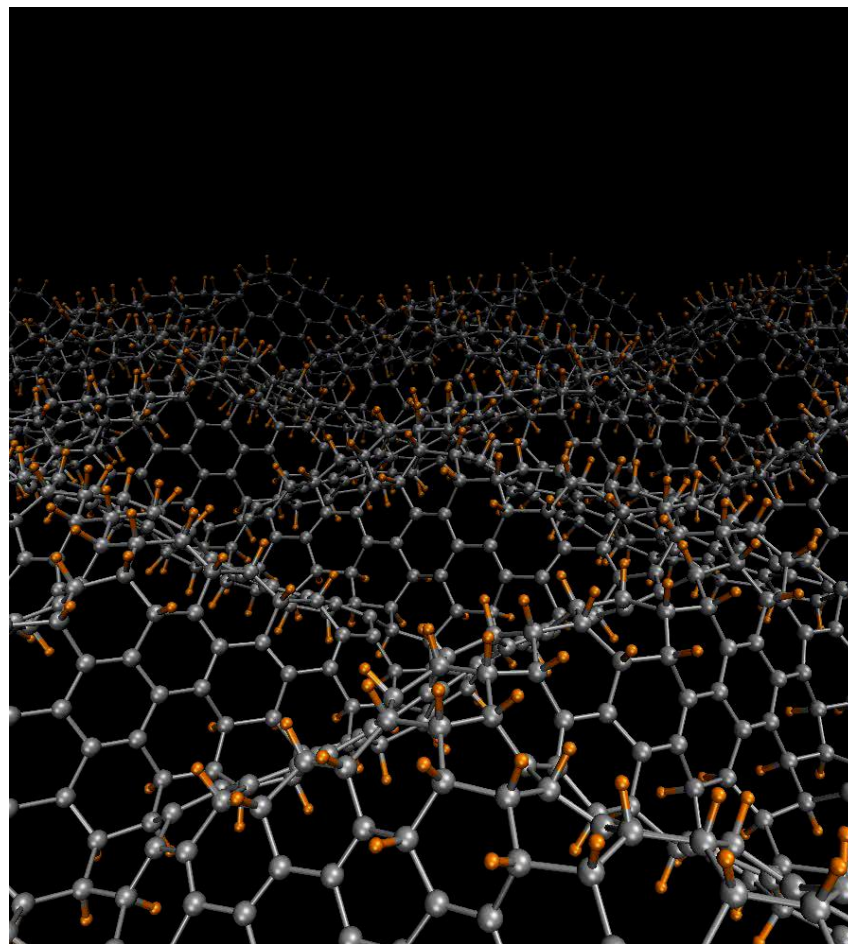

H-dimers and tetramers

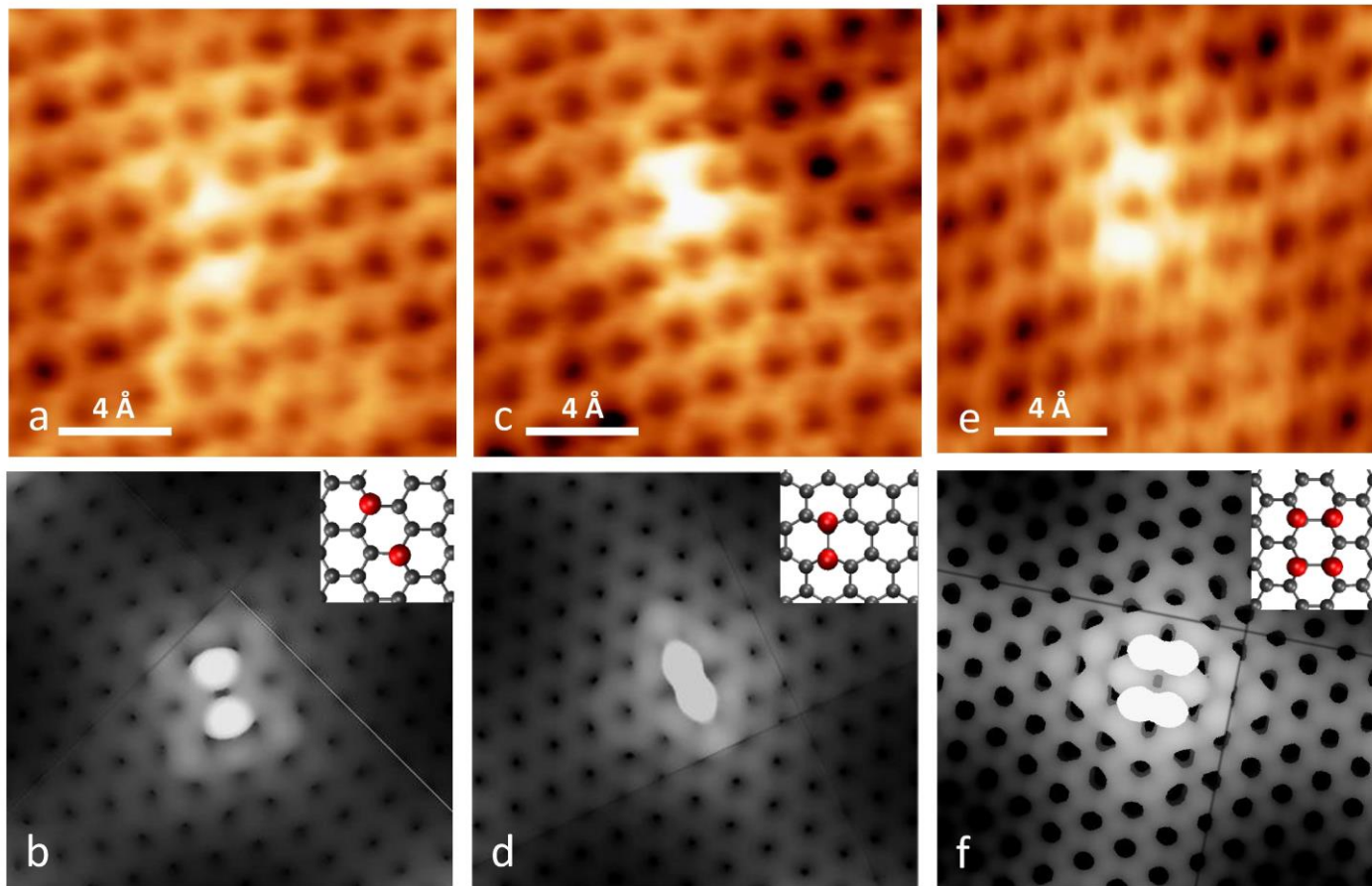

Para-dimer

Ortho-dimer

Tetramer

H adsorption and desorption

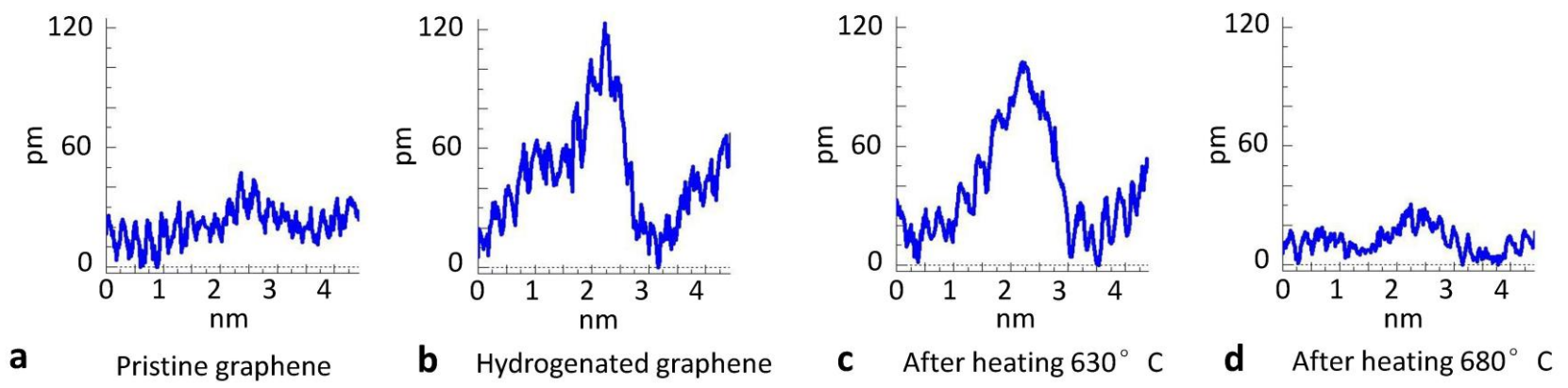
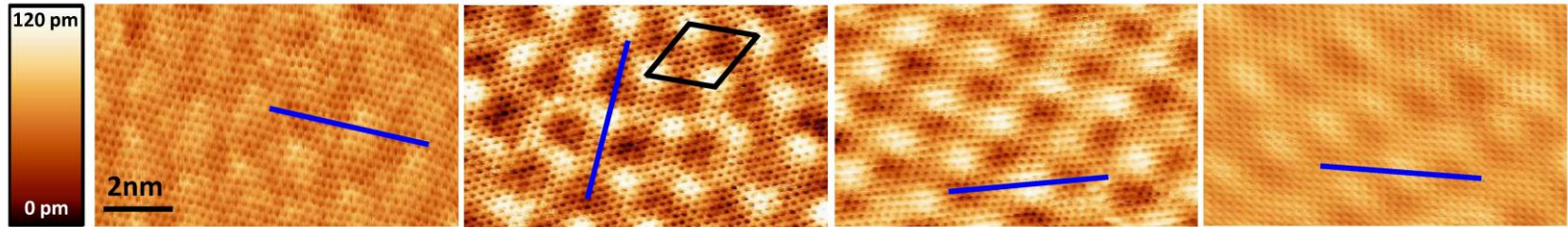

RMS roughness

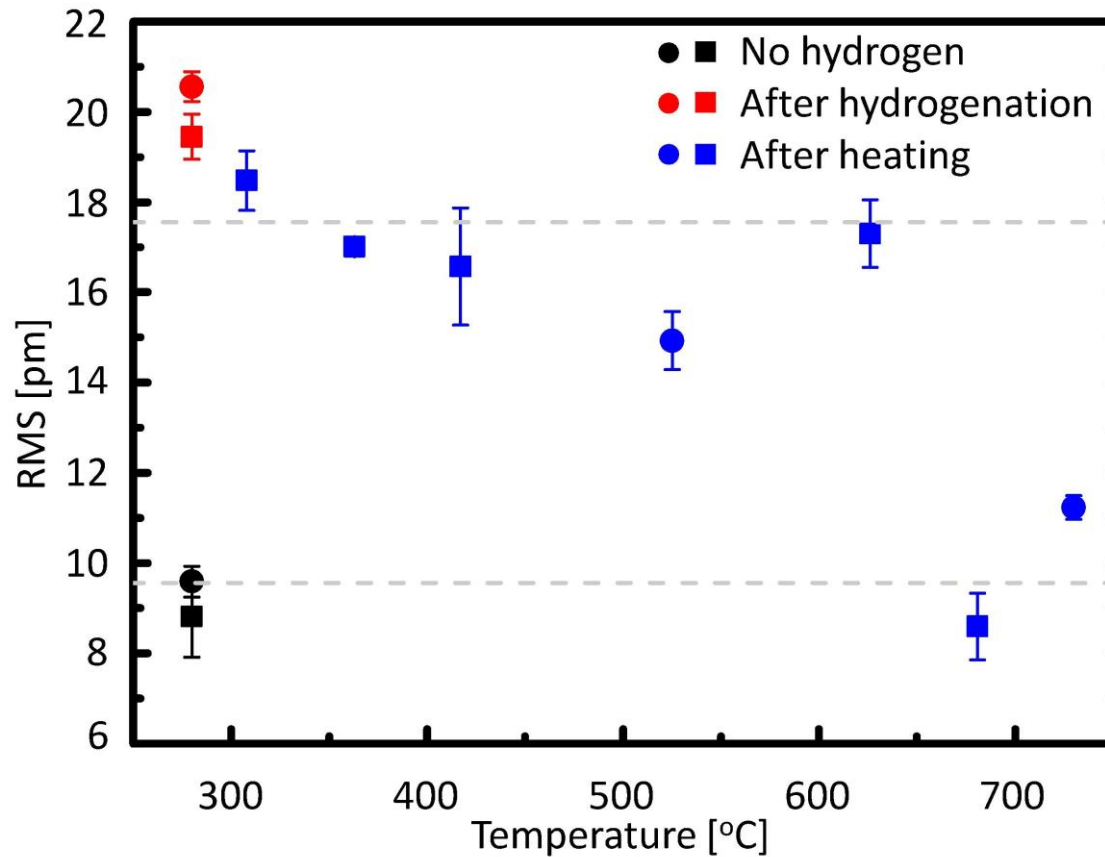

DFT calculations

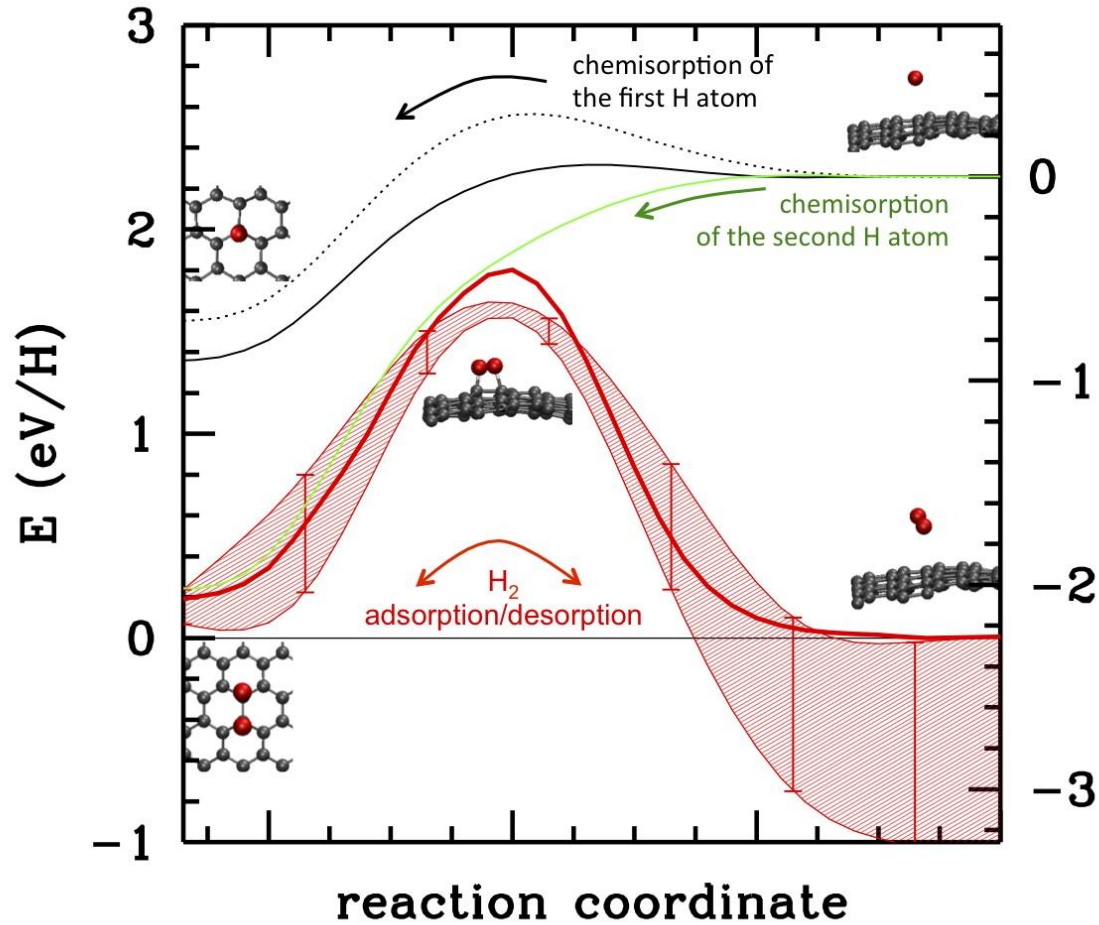

Outline

- Presentation of NEST
- Introduction to Hydrogen Storage
- Hydrogen Storage by Corrugation
- Hydrogen Storage by Functionalization

In collaboration with M. Takamura, S. Tanabe, H. Hibino

 **NTT** Basic Research Laboratories, Atsugi, Japan

 **RIKEN** Basic Research Laboratories, Atsugi, Japan
National Enterprise for nanoScience and nanoTechnology

Functionalized Graphene

- Functionalized graphene has been predicted to adsorb up to 9 wt% of hydrogen
- Modify graphene with various chemical species, such as calcium or transition metals (Titanium)

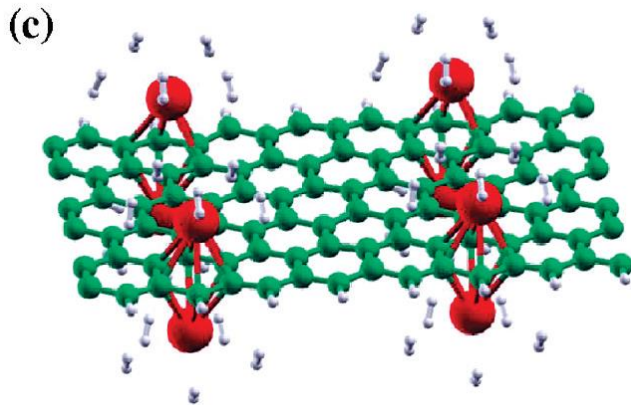

Lee et al., Nano Lett. 10 (2010) 793

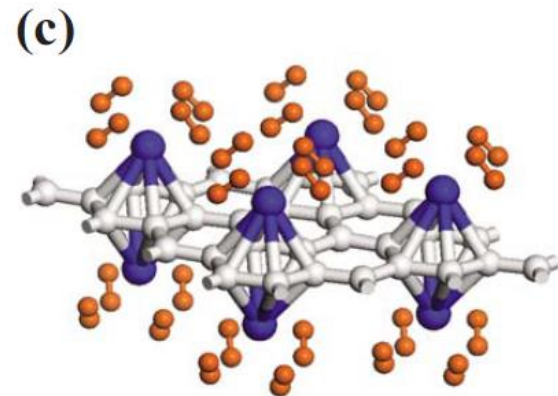

Durgen et al., PRB 77 (2007) 085405

Titanium on graphene

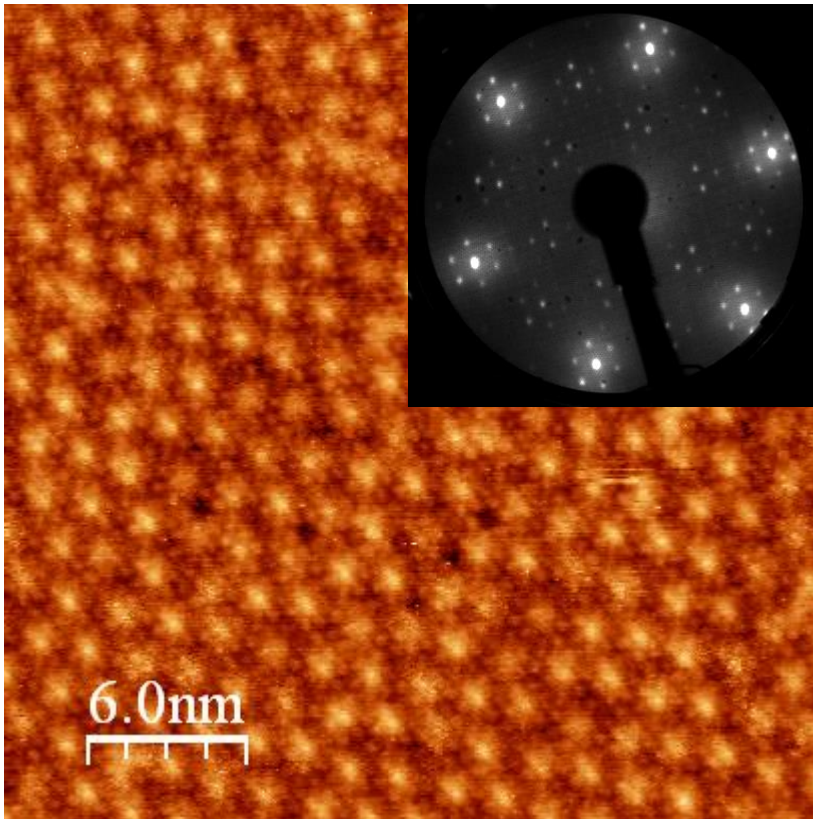

ML graphene on SiC(0001)
with reconstruction

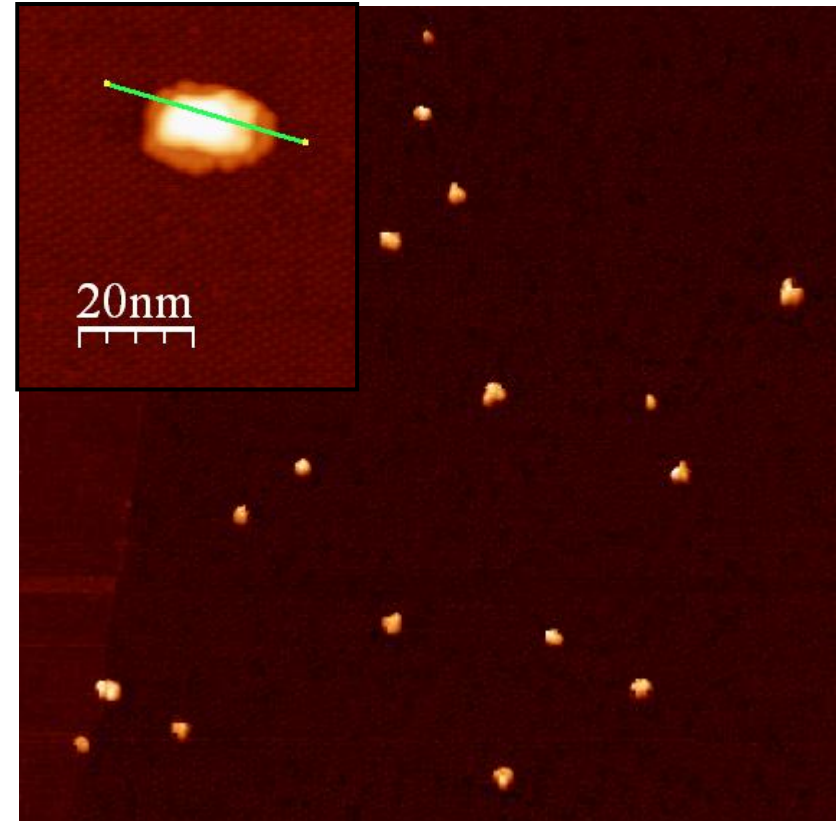

After deposition of Ti at RT

Titanium island growth

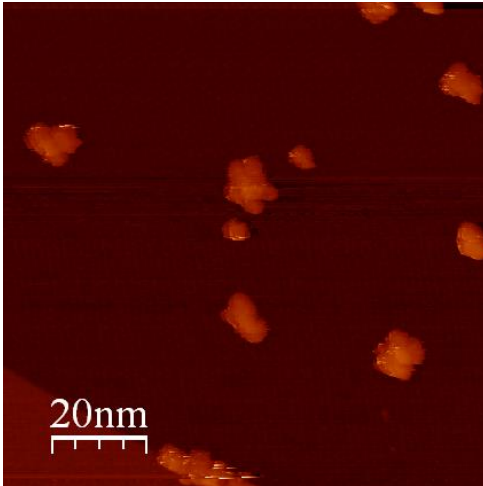

6% Coverage

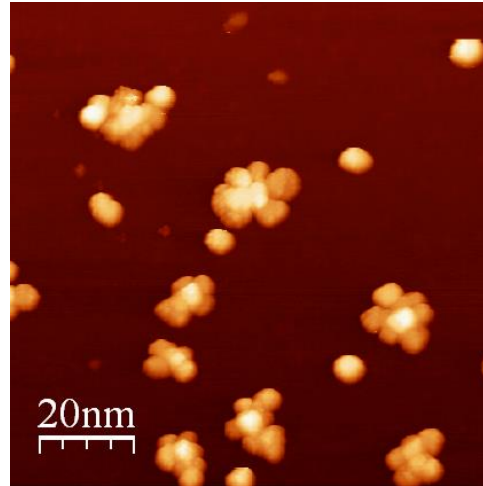

16% Coverage

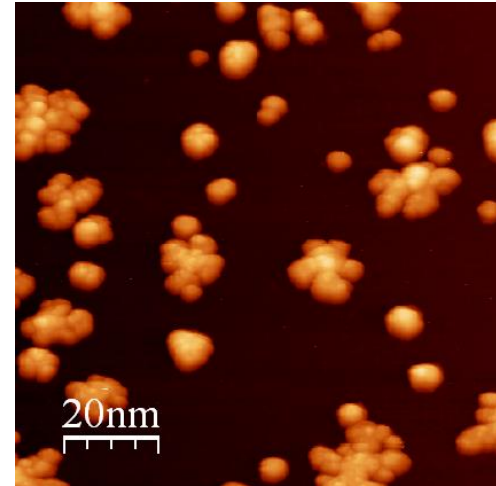

29% Coverage

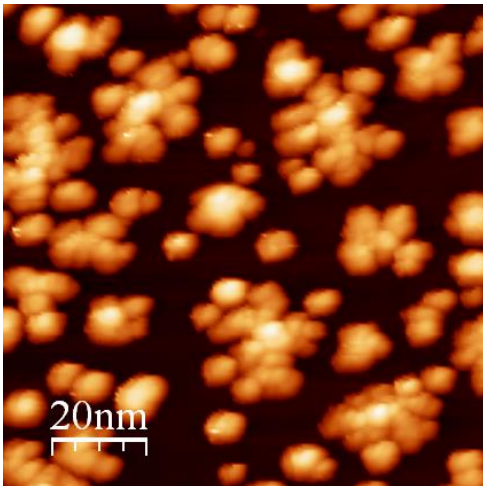

53% Coverage

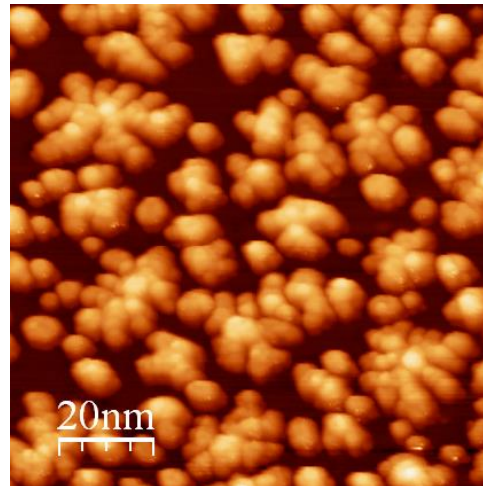

79% Coverage

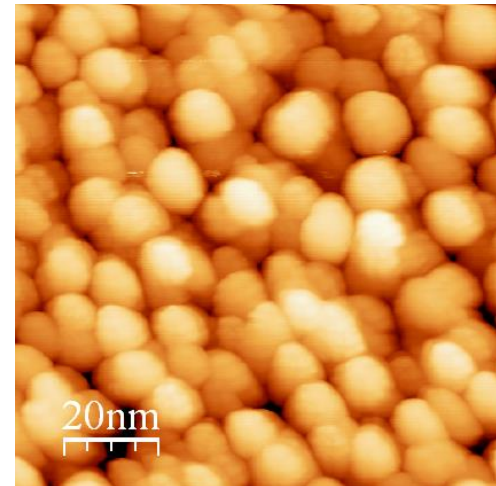

100% Coverage

Thermal desorption spectroscopy

- Deposition of different amounts of Titanium
- Offering Hydrogen (D_2)
- (1×10^{-7} mbar for 5 min)
- Heating sample with constant rate (10K/s) up to $550^\circ C$
- Measuring mass-sensitive desorption with a mass spectrometer

Spectra for different Ti-coverages

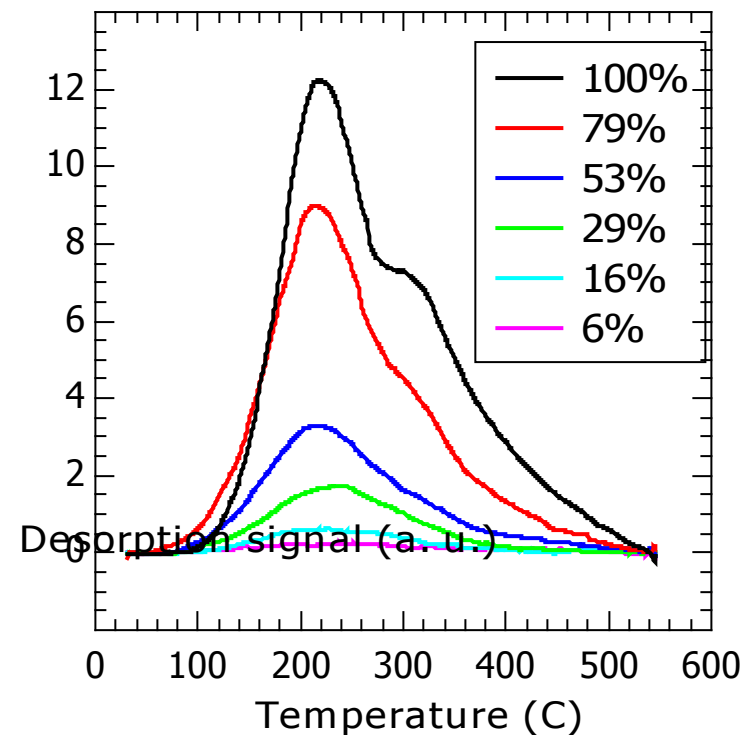

TDS peak intensity

Peak fitting

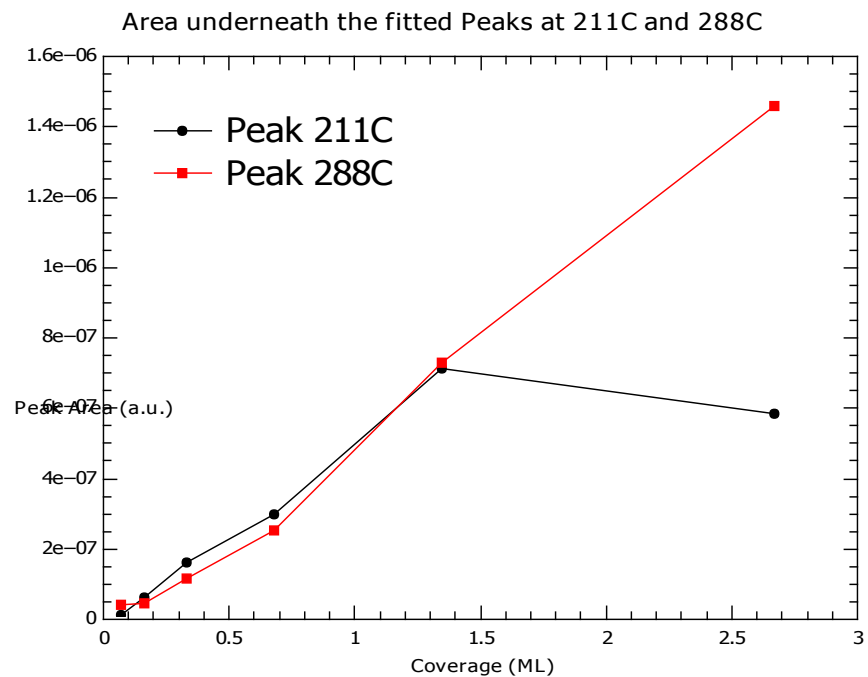
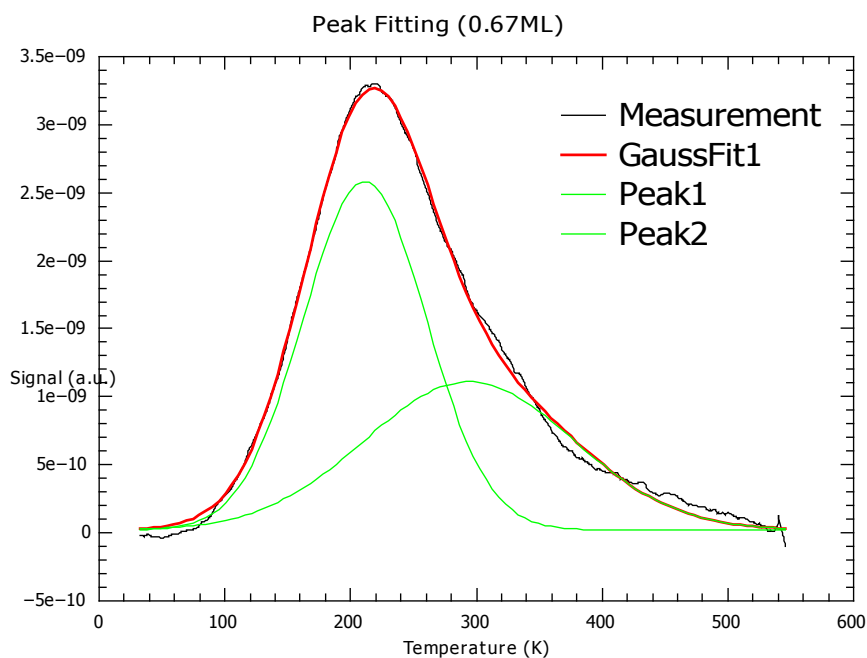

All curves could be fitted nicely with 2 peaks at 211C and 288 C

Conclusions

- Graphene is a promising material for hydrogen storage
- Curvature-dependent adsorption and desorption of hydrogen
 - reusable hydrogen storage devices that do not depend on temperature or pressure changes.
- Graphene functionalized by Ti:
 - Stability of hydrogen binding at room temperature
 - Hydrogen desorbes at moderate temperatures